

Transportable Power in Audio Cables: Energy Storage Elements and the Power Factor

by Bruce A. Brisson and Timothy A. Brisson

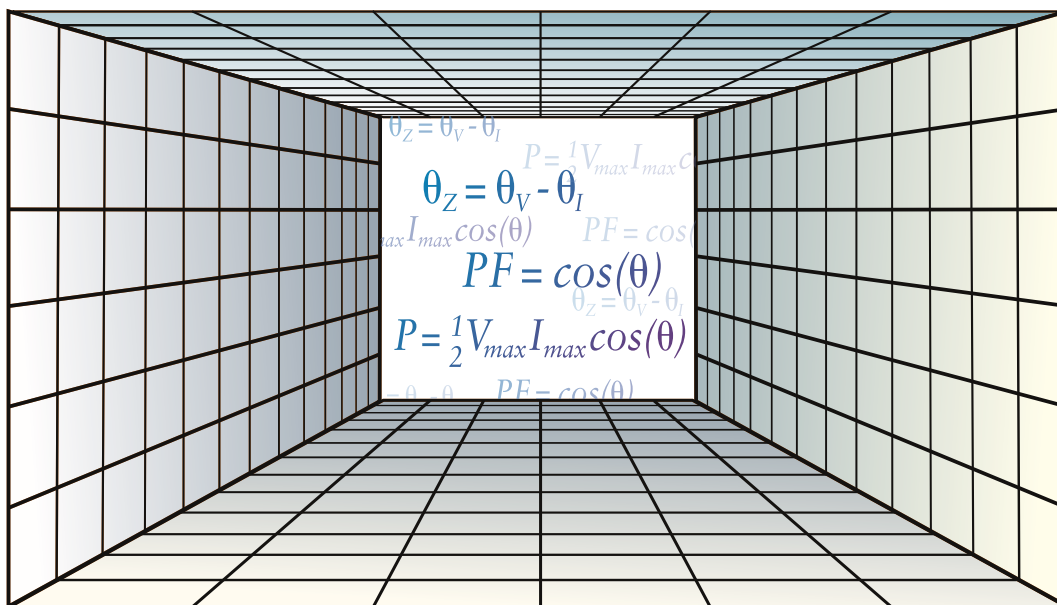

Copyright © 2006 CVTL, Inc. All Rights Reserved

How this document was produced:

Hardware: Macintosh G5 Computer System
Savin SDC413 Color Printing System with Fiery Controller

Software: *Original Graphing and Plotting applications:*
Ami Pro 2.0; SigmaPlot 4.1; Mathcad 3.0

Layout and Design:
Adobe Creative Suite: InDesign; Illustrator; Photoshop

Production: Created in-house at the MIT marketing department

Trademarks of the products listed above are held by the companies producing them.

Copyright ©1991 Bruce A. Brisson & Timothy A. Brisson

Preface

A Note on MIT's Design Criteria

For the past thirteen or fourteen years, since the first article in the audiophile press (by Jean Hiraga of France) pointed out the importance of the quality of cables in audio systems, the industry has been confused on the subject. For one thing, no industry standards exist for cables—let alone for the high end. Audiophiles and the audiophile press have continued to qualify the subject through the art of listening: Audio cables *do* sound different, and the same cable sound different in different systems. But these trained listeners have inadvertently been the second source of confusion in the realm of cables: Struggling in a world without standards, reviewers have only been able to report subjectively on what “sounds good” in *their* particular systems.

The only way to correct this confusion is to apply the proper balance of both the arts (qualification) and sciences (quantification). Audio reviewers deal in the first, and are able to qualify phenomena. Engineers deal in science and are able to quantify phenomena through applicable mathematics and test and measurement techniques.

MIT would like to begin working to bring these two realms together. Over the years, we have considered various criteria dealing with the quantification of audio cable. Throughout those years, we have adopted the following criteria in designing our cables, and suggest them as at least the beginning of a discussion of standards for the High End audio industry.

These areas are:

1. Power Domain—the rate at which energy flows
2. Frequency Domain—amplitude versus frequency
3. Time Domain—voltage versus time

With this paper, MIT is committing itself to the demystification of audio cables. We have chosen to begin with Transportable Power because, before we can consider the effects of the response of the cable in the frequency and time domains, we must first consider the development of proper active power. With that out of the way, we can then begin to examine the cable's network functions and the role they play in shaping the transfer function of the cable. In addition, we believe the discussion of power to be a natural place to include a primer on the storage elements, capacitance and inductance, and the element resistance, which are basic to understanding electronics on any level.

A note on reading this paper: In keeping with our goal to bring the art together with the science, we have included, for the engineer, a rigorous examination of the mathematics involved with power. But for the audiophile, we have expressed our concepts in as non-technical a language as possible, and with appropriate visual aids.

Bruce A. Brisson

Auburn, California

November, 1991

Table of Contents

| | |
|--|------|
| 1. Introduction | 1-1 |
| 2. Energy Storage Elements in a Network | 2-4 |
| Capacitance..... | 2-4 |
| Inductance | 2-7 |
| 3. Overview of Impedance | 3-11 |
| Definition..... | 3-11 |
| DC vs. AC Impedance..... | 3-11 |
| Conventions..... | 3-12 |
| The Role of Impedance in Audio Cable..... | 3-12 |
| 4. Impedance Characteristics of Capacitors | 4-13 |
| Ideal Case..... | 4-13 |
| Non-Ideal (Practical) Case | 4-14 |
| 5. Impedance Characteristics of Inductors | 5-15 |
| Ideal Case..... | 5-15 |
| Non-Ideal (Practical) Case | 5-16 |
| An Example: Parallel Mutual Inductance..... | 5-18 |
| 6. Power | 6-20 |
| Introduction..... | 6-20 |
| Types of Power..... | 6-20 |
| The Role of Active and Reactive Power in Audio Cables..... | 6-25 |
| 7. The Power Factor | 7-28 |
| Calculating the Power Factor | 7-29 |
| A Word of Caution About Power Factors and the Like..... | 7-29 |
| The Power Factor of Audio Cable Energy Storage Elements..... | 7-30 |
| The Power Factor of an Audio Cable Model..... | 7-32 |
| 8. Test and Measurement Results | 8-36 |
| How Tests Reveal the Characteristics of Audio Cables..... | 8-36 |
| Measurement Set-Up..... | 8-36 |
| Measurement Results..... | 8-37 |
| Conclusions from Test results | 8-40 |
| Appendix A—Capacitor Characteristics | A-41 |
| Ideal Capacitor..... | A-41 |
| Non-Ideal Capacitor..... | A-41 |
| Appendix B—Inductor Characteristics | B-42 |
| Ideal Capacitor..... | B-42 |
| Non-Ideal Capacitor..... | B-42 |
| Appendix C—References | C-43 |
| Acknowledgements | C-43 |

1. Introduction

The purpose of an audio cable in a High-End sound system is to transport musical energy between components as efficiently as possible. The rate at which energy flows is defined as power. Music Interface Technologies (MIT) has found that the power factor can be used as one measure of an audio cable's efficiency in transporting power¹ from amplifier to speaker, for example. As we will show, the power factor is calculated using the impedance phase angle of the cable, and therefore cables that exhibit improper impedance characteristics will have a poor power factor.

A High End audio cable must transport musical energy as efficiently as possible between system components. Derived from measured impedance data, the power factor can be used to quantify how effective an audio cable is in transporting power between components.

Energy is stored in an audio cable in two forms: as an electromagnetic field in an inductor, and as an electrostatic field in the dielectric of a capacitor. Electrical oscillations are produced when there is a periodic transfer of energy between the electromagnetic and electrostatic fields. This phenomenon is the basis for AC signals.

Along with the power factor, this paper will focus on the fact that music signals are AC (oscillatory) signals, not DC. In an audio cable, both inductance and capacitance are present. Energy in an audio cable is stored in two forms: in the magnetic field of the inductor and as an electric field in the dielectric of the capacitor. There is a periodic transfer of energy from magnetic form to dielectric form, and vice versa, producing electric oscillations. To understand this, the mathematics of AC analysis, such as complex impedance and complex power, must be used.

Furthermore, this paper will show that the impedance of a cable is determined not only from the resistive elements of a cable, but also from the cable's reactive or energy storage elements, namely its

¹ In this paper, when we speak of power being transported by an audio cable, we are speaking of active power—a specific type of power that will be defined later.

The AC impedance of a cable is determined not only from its resistive elements but also its reactive elements.

In this paper, when we speak of power being transported by an audio cable, we are speaking of active power a specific type of power that will be defined later.

In top-quality audio cable, proper amounts of both capacitance and inductance are present. Improper amounts of capacitance and inductance

capacitors and inductors. Finally, we will show that the power factor is a function of the impedance of the cable's reactive elements.

If the mix of capacitance and inductance in a network is not properly chosen, then audible distortion can result. An audio network is any combination of resistance, capacitance, and inductance designed to transport audio signals, such as an audio interface cable. Since capacitors and inductors oppose voltage and current changes, respectively, then an improper amount of the two will cause the network to “resist” voltage or current changes too much or too little, relative to each other. This can be observed by plotting the voltage and current as functions of time. Improper amounts of capacitance or inductance will cause either the voltage or current to be shifted on a time plot. This time shift, when measured with respect to the frequency of the input signal, is known as a phase delay, and when measured with respect to the period of the input signal, is known as the phase angle. Improper phase delay characteristics can cause a number of problems, including signal distortion (a subject of a future paper) and the focus of this paper power distortion.

This paper examines the significance of the phase angle between the voltage (capacitance) and the current (inductance) in passive coupling networks such as audio interface cables. Through the

Bad phase characteristics cause
signal and power distortions.

phase angle, insight is gained into the role the reactive elements play in a network that is storing and transporting power to a load. Actual test and measurements show how networks with an improper phase angle have problems transporting power.

Furthermore, we show how these problems can be directly analyzed by introducing and using the power factor. The power factor is shown through measurements, calculations, and plots to be an effective method of characterizing an audio cable's efficiency in transporting power to a load.

2. Energy Storage Elements in a Network

Capacitance and inductance affect a network's ability to transport power. This happens because an audio signal is an AC signal composed of fluctuating voltages and currents. Inside a cable, changing voltages cause an electric field, and changing currents cause a magnetic field. In this chapter, we will see that the capacitance in a cable interacts with the electric field, and the inductance in a cable interacts with the magnetic field. How the network's capacitance and inductance affect its voltage and current, respectively, determines in large part how power is transported by the cable.

Proper test and measurement procedures can be used to help characterize the performance of cables and coupling networks. By fully characterizing a cable or coupling network, its performance in an audio system can be specified. However, to clearly understand and interpret the results, we must first understand what it is we are measuring. Therefore, before we begin our study of power, let's take a closer look at the role capacitance and inductance play as energy storage elements in a network, specifically as related to power. Because power is defined as the rate of flow of energy, elements that store (and release) energy must have an impact on the quality of the power that is delivered to the load.

Capacitance

A capacitor is generally defined as two parallel conducting plates, usually with a dielectric between them; the symbol is shown in Fig. 2-1. Audio cable is constructed similarly, usually in one of three ways: a two-conductor cable (zipcord, for example), a coaxial cable (a center conductor surrounded by a braided shield), or a twisted pair. In most High End cables, including MIT's, the construction is usually a twisted pair the two conductors being twisted around one another.

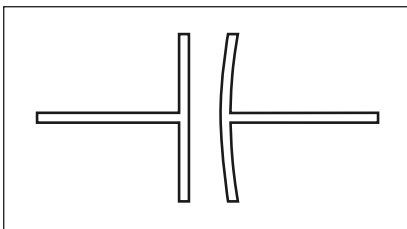

Figure 2-1. Circuit symbol for an ideal (lossless) capacitor. An ideal capacitor is linear and time invariant.

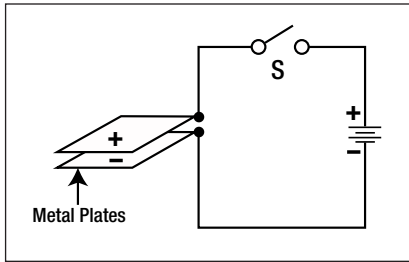

Figure 2-2. Parallel plate capacitor connected to battery.

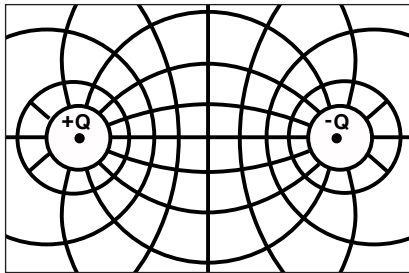

Figure 2-3. Electric field lines created by the separation of charges $+Q$ and $-Q$

Electrostatic energy is stored within an audio cable in its shunt capacitance. At low frequencies, even though no current is flowing through the shunt capacitance in an ideal cable energy is still being stored because of the potential difference between the conductors

The shunt (or parallel) capacitance in an audio cable arises from the proximity of the two conductors. From the point of view of capacitance, a two-conductor audio cable can be thought of as two long, skinny parallel plates close to each other. To understand how a capacitor stores energy, imagine the following: Suppose a battery is connected to a capacitor, as in Fig. 2-2. When the switch S is closed, almost instantly the capacitor will be “charged,” that is, positive charges will accumulate on the side of the capacitor connected to the positive side of the battery, and negative charges will gather on the side of the capacitor connected to the negative side of the battery. Now there is a “separation of charges.” The positive and negative charges are separated by the distance between the plates. The theory of electrostatics tells us that any separation of charges creates an electric field, as shown in Fig. 2-3. If this is an ideal capacitor, when the battery is disconnected the charges will remain on the plates, and thus the electric field will remain. Since an electric field is a form of potential energy, energy has been stored in the capacitor. Electrostatic energy in an audio cable is stored in its shunt capacitance.

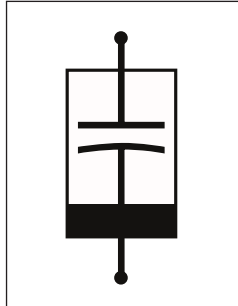

Figure 2-4. Non-linear capacitor circuit symbol.

The mathematical definition for capacitance (C) is

$$C = \frac{Q}{V}$$

where Q is the amount of charge on one plate in coulombs, and V is the potential difference between the plates in volts. The unit of capacitance is the farad (F).

If the value of capacitance C does not remain constant with different values of applied voltage, then the capacitor is said to be non-linear. If the value of the capacitor changes with the applied frequency, then the capacitor is time-varying. Therefore, an ideal capacitor is linear and time-invariant. The symbol for a non-linear² capacitor is shown in Figure 2-4. A linear capacitor will have superior power characteristics when compared to a non-linear capacitor.

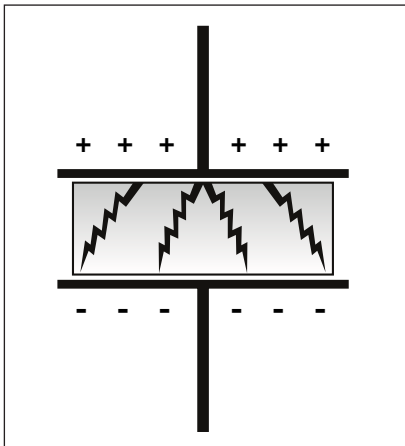

Figure 2-5. An ideal dielectric stores energy and does not dissipate it

(In general, a component that is either non-linear or time-varying is simply said to be non-linear)

The material between the two plates is known as the dielectric, or insulator. Typical dielectrics include air, various plastics, Teflon, mylar, paper, and rope or twine. Glass and Styrofoam are also good insulators.

² In general, a component that is either non-linear or time varying is simply said to be non-linear.

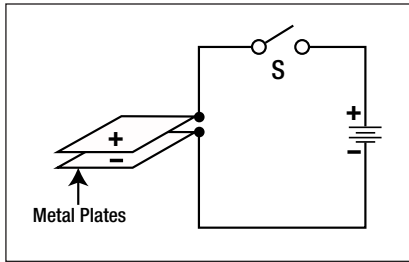

Figure 2-2. Parallel plate capacitor connected to battery.

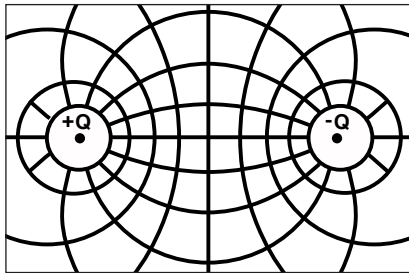

Figure 2-3. Electric field lines created by the separation of charges $+Q$ and $-Q$

Electrostatic energy is stored within an audio cable in its shunt capacitance. At low frequencies, even though no current is flowing through the shunt capacitance in an ideal cable energy is still being stored because of the potential difference between the conductors

The shunt (or parallel) capacitance in an audio cable arises from the proximity of the two conductors. From the point of view of capacitance, a two-conductor audio cable can be thought of as two long, skinny parallel plates close to each other. To understand how a capacitor stores energy, imagine the following: Suppose a battery is connected to a capacitor, as in Fig. 2-2. When the switch S is closed, almost instantly the capacitor will be “charged,” that is, positive charges will accumulate on the side of the capacitor connected to the positive side of the battery, and negative charges will gather on the side of the capacitor connected to the negative side of the battery. Now there is a “separation of charges.” The positive and negative charges are separated by the distance between the plates. The theory of electrostatics tells us that any separation of charges creates an electric field, as shown in Fig. 2-3. If this is an ideal capacitor, when the battery is disconnected the charges will remain on the plates, and thus the electric field will remain. Since an electric field is a form of potential energy, energy has been stored in the capacitor. Electrostatic energy in an audio cable is stored in its shunt capacitance.

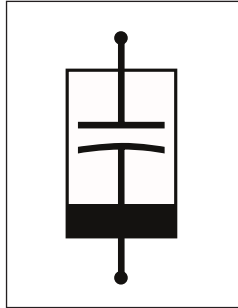

Figure 2-4. Non-linear capacitor circuit symbol.

The mathematical definition for capacitance (C) is

$$C = \frac{Q}{V}$$

where Q is the amount of charge on one plate in coulombs, and V is the potential difference between the plates in volts. The unit of capacitance is the farad (F).

If the value of capacitance C does not remain constant with different values of applied voltage, then the capacitor is said to be non-linear. If the value of the capacitor changes with the applied frequency, then the capacitor is time-varying. Therefore, an ideal capacitor is linear and time-invariant. The symbol for a non-linear² capacitor is shown in Figure 2-4. A linear capacitor will have superior power characteristics when compared to a non-linear capacitor.

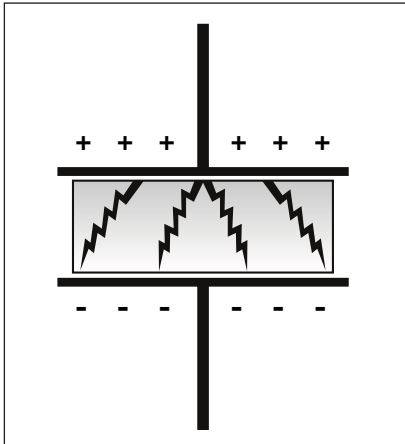

Figure 2-5. An ideal dielectric stores energy and does not dissipate it

(In general, a component that is either non-linear or time-varying is simply said to be non-linear)

The material between the two plates is known as the dielectric, or insulator. Typical dielectrics include air, various plastics, Teflon, mylar, paper, and rope or twine. Glass and Styrofoam are also good insulators.

² In general, a component that is either non-linear or time varying is simply said to be non-linear.

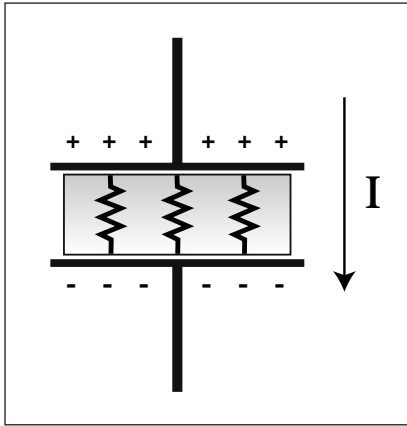

Figure 2-6. A real-world dielectric allows a small amount of current to leak between the plates, causing some power loss

The energy between the plates of a capacitor is stored in the dielectric.

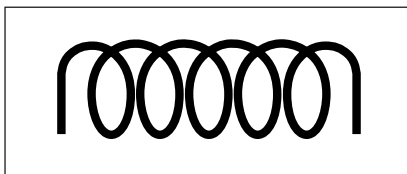

Figure 2-7. Circuit symbol for an ideal (lossless) inductor. An ideal inductor is linear and time-invariant

Ideal dielectrics, such as a perfect vacuum, conduct no electricity, as shown in Figure 2-5. Thus, ideally, there would be an open circuit (infinite resistance) between the plates of a capacitor. In the real world, however, the dielectric has some finite resistance, and therefore is not a perfect insulator. This allows some of the electric charge to “leak” between the plates, as shown in Figure 2-6, and is aptly known as the leakage current.

The function of a dielectric is to store energy. As we said earlier, energy is stored in a capacitor between its plates. Since the dielectric is between the plates, energy is stored in the dielectric. Therefore, if the dielectric allows leakage current, then energy is being lost. This would then be a lossy capacitor. Lossy capacitors have poor power transfer characteristics.

Inductance

Inductance is one of the least understood, but most important, properties of audio cable. Typically, most High-End cable companies use the highest quality dielectrics when constructing their cables. Therefore, most High-End audio cables have good capacitive characteristics, as related to power. However, most widely miss the mark when it comes to the required inductive component. Without a proper inductive component, current cannot be

As we will see later, a requirement for top-quality audio cable is the proper amount of inductance. Without inductance, an audio cable will not be able to efficiently transport power. This is because of the shunt capacitance present in all audio cables.

A coil becomes an inductor through a property called self-inductance. Inductors resist changes in current through inductance. By resisting current changes, an inductor attempts to maintain a constant current through itself.

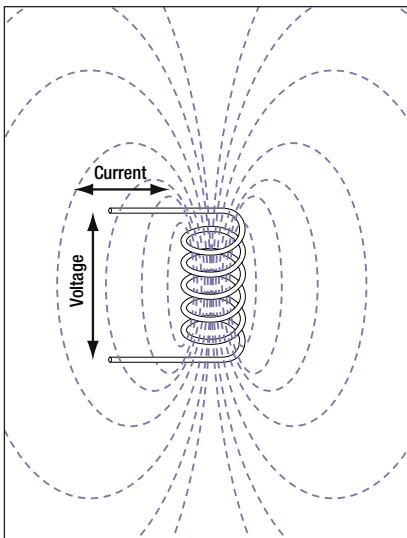

Figure 2-8. Magnetic field produced by an inductor, showing current being stored within the field.

stored, and the cable will have difficulty transporting active power to the load.

An inductor is usually constructed as a coil of wire, and the symbol for an ideal (linear) inductor (Figure 2-7) reflects this. A coil acts as an inductor through a property called self-inductance commonly called simply inductance, the tendency of a current in a loop to maintain itself. Current flowing through a coil produces a magnetic field, as shown in Figure 2-8. An inductor opposes changes in current through the following process: If the current in the first turn of the coil changes, the magnetic flux it produces around it also changes, and a voltage is induced in the adjacent turn (changing magnetic fields create electric fields and thus voltage potentials). But since a voltage has been induced into the neighboring turn, current has also been induced into it. But the increased current in the adjacent turn creates more magnetic flux around itself. Now this increased magnetic flux around the second turn tries to induce more current back into the first turn, thus attempting to oppose the initial rise in current. While the capacitor stores energy in its electric field, the inductor stores energy in its magnetic field. The mathematical relationship for

The equation for inductance shows that it is current sensitive. That is, an inductor behaves differently for varying levels of current.

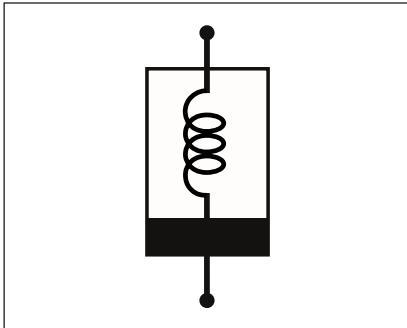

Figure 2-9. Non-linear inductor symbol.

Constructing a cable with many coils of wire is like winding an inductor.

The geometry of the cable windings determine its self-inductive properties. therefore, a single strand of wire can produce different amounts of inductance simply by being wound differently .

inductance (L) is given by

$$L = \frac{V}{\frac{di}{dt}}$$

where v is the voltage potential across the inductor in volts, i is the current in amps, and t is the time in seconds. The symbol $\frac{di}{dt}$ reads “change in current with respect to time.” Thus, the equation for inductance relates the voltage across the inductor, to the time rate of change of current through it. The unit of inductance is the Henry (H). If the value of inductance L does not remain constant with different values of applied current, then the inductor is said to be non-linear. If the value of the inductor changes with the applied frequency, then the inductor is time-varying. Thus, an ideal inductor is linear and time-invariant. The symbol for a non-ideal inductor is shown in Figure 2-9.

Since a High-End audio cable is typically constructed with many coils of wire, constructing a cable is like constructing an inductor. In fact, it is during the winding process that the important element of inductance is added. Because proper inductive qualities are so important to a cable’s performance, the inductive component must be artfully formed by carefully controlling the geometry of the windings during fabrication. Inductance is controlled by the size, spacing, and length of the wires, the bundle and conductor size, and how many turns are wrapped per unit length (angle of lay).

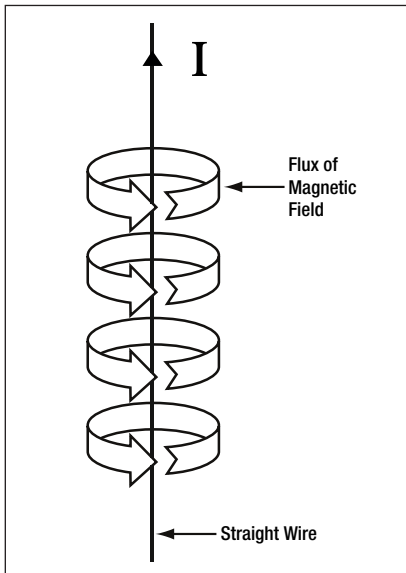

Figure 2-10. Magnetic field lines around a straight wire. The flux lines of the stored current do not cut the wire, showing a low value of self-inductance, and correspondingly low density of current being stored.

Figure 2-10 shows the magnetic field produced by a straight wire. Notice that the field lines do not cross, or cut, through the wire at any point. This shows that a straight wire has poor self-inductive qualities. But look how the field lines in the coil of Figure 2-11 cut through the coil many times. The field lines around an inductor give a direct indication of how much inductance the inductor is producing. The more flux lines produced for a given input, the more inductance is produced, and the more current is stored in the inductor. Thus a coil has more inductance, and therefore stores more current, than a straight wire.

Audio cables constructed mainly of straight wires have poorer inductive characteristics than coiled cables which means that straight wires have poorer power characteristics than coiled cables.

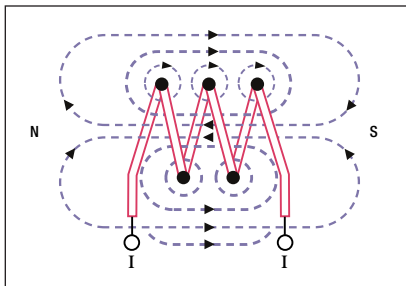

Figure 2-11. A close-up of the magnetic flux in an inductor showing interaction of neighboring coils. The many coils of wire create numerous flux lines that link together, thereby creating a higher-density current field than that of the straight wire of Figure 2-10. A coiled wire therefore has better self-inductive properties (and stores more current) than a straight wire. As related to audio cables, then, better inductive qualities mean better power characteristics. Thus a coiled wire will transport power more efficiently than a straight wire.

Many of MIT's proprietary techniques, patents deal specifically with constructing audio cable in a manner that creates optimum self-inductive qualities.

3. Overview of Impedance

Definition

Impedance is the total opposition, offered by resistance and reactance, to an AC signal.

Impedance is defined as the opposition to alternating current flow. Since the purpose of audio cable is to pass musical signals unopposed (or uniformly opposed), understanding impedances in cable is crucial. It is from the impedance characteristics of a cable that the cable's performance can be calculated.

It is outside the scope of this paper to fully explain impedance in fact, impedance will be the subject of a subsequent paper. For further information on this subject, or complex numbers, references on these subjects are included in the bibliography.

DC vs. AC Impedance

Since audio cables carry musical signals, which are AC signals, audio cables must be characterized using AC mathematics. Furthermore, AC impedance cannot be measured with the same type of instrumentation used to measure DC. A DC Ohm meter cannot be used to find the power factor of audio cable.

In the introduction, we stated that musical energy in a cable is AC energy. It is therefore improper to characterize audio cables using DC methods. One of the most common mistakes in analyzing audio cable is to use a standard multi-meter, which measures the DC resistance of the cable. The impedance of audio cable must be determined using an AC impedance analyzer. This type of equipment measures the impedance of a device at a specific frequency and gives not only the magnitude of the impedance, but also the phase angle of the impedance. As we will see shortly, it is this measured phase angle that is of great interest to us/we will use it to calculate the power factor.

The impedance phase angle measurement of audio cable yields important information. The power factor analyzed in this paper is calculated using the impedance phase angle.

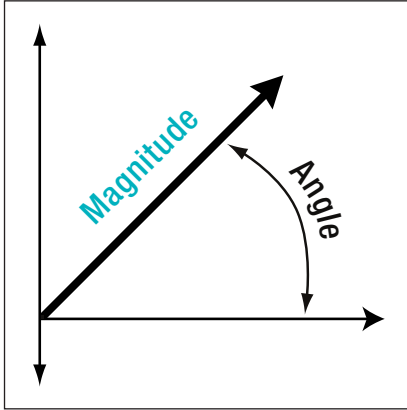

Figure 3-1. Impedance is a vector, with an angle as well as a magnitude. The angle is used in the calculation of the power factor.

Virtually everything you want to know about a network, including power, frequency-domain analysis, and time-domain analysis, can be computed from the network's impedance.

Conventions

In this paper, impedance will be represented in phasor notation; that is, impedance is given in polar coordinates as a vector of magnitude Z and phase angle θ . The unit of impedance, whether purely resistive (as an ideal resistor) or reactive (as with energy storage elements), is given in ohms. If Figure 3-1 had a length of 1 and a phase angle of 45 degrees, the phasor notation would then be written

$$\vec{Z} = 1\Omega \angle 45^\circ$$

and read as: “An impedance of 1 ohm at 45 degrees.”

The Role of Impedance in Audio Cables

The key to understanding the behavior of a network, such as an audio cable, lies in understanding its impedance characteristics. Once the impedance is known, all else follows power characteristics, transfer functions, etc.

4. Impedance Characteristics of Capacitors

Ideal case

An ideal capacitor has an impedance phase angle of -90 degrees that does not change with frequency or applied voltage. If it does, the power factor will suffer.

When referenced to time, the voltage across a capacitor lags behind the current.

Capacitive reactance, as with resistance, is given in units of ohms. However, unlike a pure resistor, the value of capacitive reactance changes with frequency

An ideal capacitor has an impedance phase angle of -90 degrees that remains constant with frequency and applied voltage. This means that the voltage across a capacitor falls behind, or “lags,” the current going through it by 90 degrees, or one-quarter of a cycle. Since a capacitor opposes changes in voltage, it makes sense that the voltage is delayed behind the current. Appendix A, Figure 2, shows the relation between voltage ($v(t)$) and current ($i(t)$) for an ideal capacitor. Note how the peaks in the current waveform are a quarter-cycle to the left of (leading) the voltage waveform.

Appendix A, Figure 1 shows an impedance plot for the ideal capacitor on the complex plane. Since the phase angle is -90 degrees, the capacitive-reactance vector points straight down. The phasor for an ideal capacitor is then:

$$\vec{Z}_c = X_c[\Omega] \angle 90^\circ$$

where X is the capacitive reactance, and is found from:

$$X_c = \frac{1}{2\pi fC} [\Omega]$$

where f is the applied frequency in Hertz (Hz), and C is the capacitance in farads (F). Capacitive reactance is given in units of

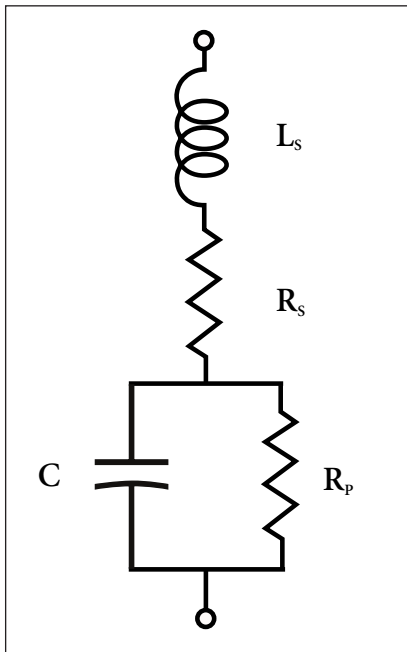

Figure 4-1. Equivalent circuit for a practical capacitor. L_s , R_s , and R_p are parasitic components, and represent the parasitic losses for a practical capacitor. Parasitics are unwanted adjuncts of wanted circuit elements. When a component's electrical behavior deviates from the ideal, parasitics are used to model the observed losses. The values of these parasitics can change drastically with frequency

In this paper, we show that parasitics, along with poor self-inductive qualities, are the underlying cause of the poor power factor seen in most audio cables at low audio frequencies. Parasitics bring about a loss of impedance phase angle in audio cables, resulting in less-than-ideal power transfer characteristics.

ohms (Ω). Note: The impedance of a capacitor is not constant to frequency, as is an ideal resistor. This is because capacitive reactance changes with frequency.

Non-Ideal (Practical) Case

The non-ideal model takes into account the real-world losses of the dielectric. This is done through the use of parasitics, as shown in Figure 4-1. Parasitics are unwanted adjuncts of wanted circuit elements, such as resistance or inductance. All real-world components have parasitics. The net effect of parasitic resistance normally seen in audio cables is the loss of one-half of one degree, to one and one-half degrees off the capacitance phase angle. Typical values for parasitic resistances (R_p) are usually on the order of several Mohms, though these too can be frequency dependent and vary widely. However, -89.5° is a typical non-ideal capacitance phase-angle value for an audio cable when measured at audio frequencies. Therefore, the capacitive component of high-quality audio cable normally does not vary far from the ideal within the audio frequency range. This is not the case with the inductive component, as we will see next.

5. Impedance Characteristics of Inductors

Ideal inductors have an impedance phase angle of +90 degrees, which remains constant with frequency and applied current. As with capacitors, if the phase angle varies from the ideal, the power factor will also vary.

The current through an inductor lags behind the voltage across it in time.

Inductive reactance also has units of ohms(Ω). Unlike a pure resistor, the inductive reactance value changes with frequency.

Ideal case

An ideal inductor has an impedance-phase angle of +90 degrees that remains constant with frequency and applied current.

Opposite to the capacitor, the inductor's voltage leads the current by 90 degrees. Or from the other point of view, the current in an inductor lags the voltage by 90 degrees. Using the same logic we applied to the capacitor earlier, since an inductor opposes changes in current flow, we would expect that the current in an inductor would be delayed one-quarter of a cycle. This is the compliment of the capacitor, where the voltage was delayed a quarter cycle.

Appendix B, Figure 2 shows the voltage and current waveforms of an ideal inductor. Compare with Appendix 1, Fig. 2. The phasor for an ideal inductor is:

$$\vec{Z}_L = X_L[\Omega] \angle +90^\circ$$

where X_L is the inductive reactance, and is found from

$$X_L = 2\pi fL \quad [\Omega]$$

where f is the frequency in Hertz (Hz), and L is the inductance in Henrys (H). Note that the inductive reactance changes with frequency, just like (but inverse to) capacitive reactance. The phasor

Parasitic capacitance occurs between the coils of inductors. Parasitic capacitance is a major cause of power-factor loss in audio cable.

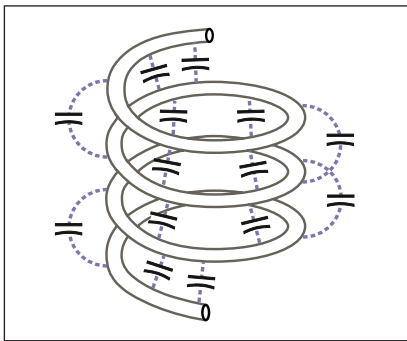

Figure 5-1. Parasitic capacitance between the windings of an inductor. This phenomenon is known as parallel (or mutual) capacitance and denoted C_p .

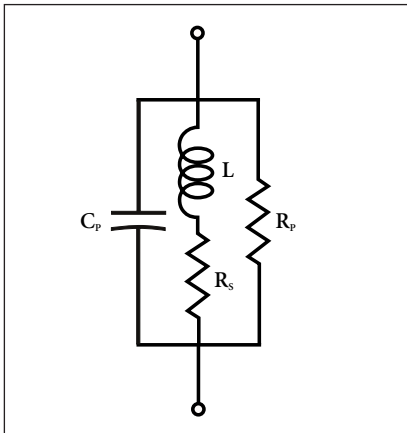

Figure 5-2. Equivalent circuit of a practical inductor. C_p , R_p , and R_s represent the parasitic losses. The effect of these parasitics, especially C_p , becomes very dramatic at low frequencies.

diagram for an ideal inductor is shown in Appendix B, Figure 1. Note that it points straight up.

Non-Ideal (Practical) Case

The non-ideal model takes into account two things: the resistance of the coil of wire and the capacitance between the inter-coil windings. The former is easy to understand; this is the resistance found from the measurements made with the impedance analyzer. But the latter is a little more difficult to understand. Recall from the discussion of capacitance that the proximity of conductors generated the cable's shunt capacitance. The windings of an inductor are in close proximity also. Therefore they have their own parasitic capacitance. Figure 5-1 shows this effect. Along with poor self-inductive qualities caused by improper winding techniques, the loss of inductive phase angle (and therefore power factor) seen at low audio frequencies can be attributed to parasitic capacitance between the windings of audio cable.

The real-world model of an inductor is shown in Figure 5-2. This model includes the resistance of the windings (R_s) along with the parasitic capacitance (C_p). While the parasitic resistance of the capacitor (R_p primarily) normally has the effect of knocking only

Poor self-inductive properties, due primarily to improper winding of the cable, and parasitic capacitance are the main culprits responsible for the loss of inductive phase angle in audio cable at low audio frequencies. This loss of phase angle causes a higher (worse) power factor.

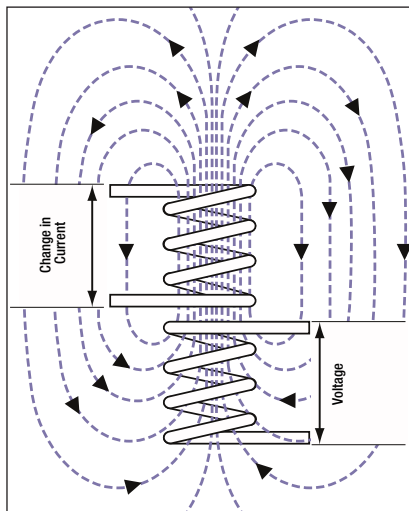

Figure 5-3. AC signals need not pass through a continuous or solid network. This figure shows how the magnetic flux lines link up to pass AC signals when the network is not directly connected. This is the principle behind a simple transformer.

Rather than relying on self-inductance alone to create the inductance in an audio cable, MIT utilizes mutual inductance, also. By adding mutual inductance, better phase-angle characteristics can be maintained at lower frequencies, leading to a more constant power response through the audio spectrum.

a half-degree off the ideal -90 degree reading, the effects of the parasitics on an inductor operating at low audio frequencies are much more dramatic.

Most audio cables have problems in this area between zero Hertz (DC) and 1 kHz. It is not uncommon for audio cable with poor inductive characteristics to lose nearly all of the inductive phase angle at low frequencies (<100 Hz). Such a deviation from the ideal is shown in the non-ideal phasor diagram in Appendix B, Figure 3. This loss of inductive phase angle has tremendous implications on audio quality.

By coiling the wire of a cable in a tight loop, MIT helps to overcome the problems of self-inductance by creating proper amounts of inductance in the cable through proprietary patents and patent-pending winding techniques. Additionally, MIT achieves better inductive properties through mutual inductance.

Mutual inductance occurs when the flux of two independent, non-connected coils interact. Figure 5-3 shows this effect in a common transformer. In fact, mutual inductance is the basis for the operation of transformers. When the magnetic flux of two coils interacts in a positive (additive) manner, they have positive *mutual inductance*. When the magnetic flux of two coils interacts in a negative (canceling) manner, the two coils have negative mutual

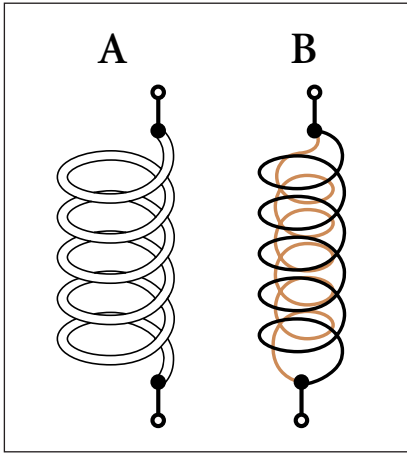

Figure 5-4. Two networks constructed with coils wound differently.

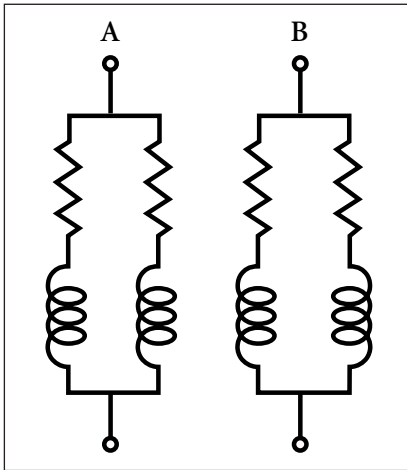

Figure 5-5. Network A shows two parallel inductors resulting in a positive value of M , or mutual inductance. Network B shows two parallel inductors resulting in a negative value of M . Network A depicts a desirable winding configuration of properly constructed audio cable.

inductance. Mutual inductance is noted with the letter M , which has units of Henrys (H).

[An Example: Parallel Mutual Inductance](#)

Figure 5-4 shows a pair of two-terminal networks constructed with coils wound in parallel. In this example, rather than mathematically derive the equivalent inductance, we will show how the network can be modeled with equivalent circuits.

Figure 5-5 shows the two coils of Figure 5-4 schematically, including their parasitic series resistance. Note how the coils (composed of the strands of copper wire within a multi-stranded cable) of Network A are wound in the same direction, while the coils of Network B are wound in the opposite direction. Figure 5-6 shows that Network A reduces to a series inductor/resistor combination. Since an inductor is present in the final equivalent circuit, a series impedance phase angle is present. This is necessary for a good power factor. Network B, however, reduces to a series resistor only in Figure 5-7. Therefore, a cable wound in the manner of B will produce no inductance, and therefore will hold no inductive phase angle. This will lead to a poor power factor. This is because all audio cables inherently have shunt capacitance,

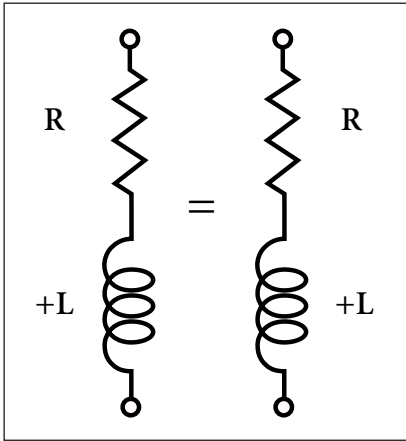

Figure 5-6. Network A reduces to a series inductor and resistor, leading to a desirable power factor.

and an inductive phase angle is therefore necessary to balance the shunt capacitor's phase angle.

MIT has investigated many methods of winding audio cable to find the optimum techniques that produce proper inductive qualities necessary for audio cable to transport active power efficiently. Since inductance is such a misunderstood subject, as related to audio cables, MIT has committed itself to publish articles on this subject in a continuing effort to demystify it.

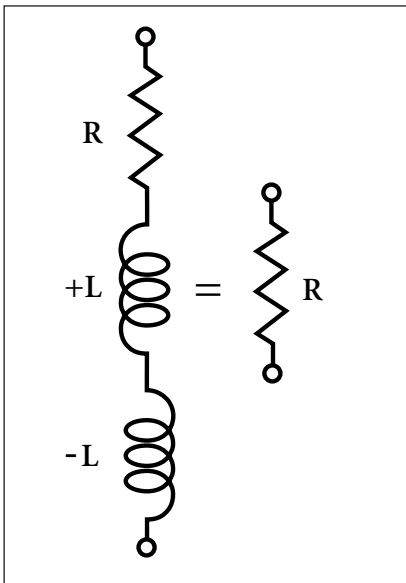

Figure 5-7. Network B reduces to a network consisting of two series inductors and a series resistor. The series inductors cancel out, leaving the equivalent circuit for Network B as a series resistor only. For a typical audio cable measured on a conventional DC Ohm-meter, this resistor would have a value of but a few tenths of an Ohm. But because of the shunt capacitance that is present in all audio cables, this combination will result in a poor power factor.

6. Power

Since music is composed of AC signals, DC mathematics is not applicable in calculating AC power.

When most people discuss power, they usually are speaking of DC power. In this case, the power is easy to calculate it is simply the voltage times the current. However, we do not listen to DC on our audio systems. Therefore, it is incorrect to characterize audio cables used in transporting AC signals with DC mathematics. Unfortunately, the mathematics of AC power is more complicated than DC. Let us define the several types of AC power and how they apply to audio cables.

Types of Power

► Power (General Definition):

Power is the rate of flow of energy. The unit of power is the watt (W), which is one joule per second. Electrical power, in general, is calculated by multiplying voltage times current.

► Apparent Power:

Apparent power is found from the product of the rms value of the applied voltage and the rms value of the applied current. Thus, as related to audio, apparent power represents the total value of the power supplied by the source.

Power is the time rate of energy absorption

As related to audio cables, apparent power is that power supplied by the source to the cable.

► Instantaneous Power:

Instantaneous power is calculated by multiplying the values of voltage and current at each point in time.

Instantaneous power is defined mathematically as:

$$p(t) = v(t) i(t) \quad [\text{W}]$$

Thus, this is the power being consumed or delivered by a device or network at one instant in time. The AC signals that compose audio can be expressed as sinusoidal functions of time.

The voltage is:

$$v(t) = V_{\max} \cos(\omega t + \theta_v) \quad [\text{V}]$$

Note how the formulas for voltage and current have the respective phase angles in them. This is because they are AC signals. Therefore, when the voltage and current are multiplied together to calculate instantaneous power, the phase angles must be factored in.

and the current becomes:

$$i(t) = I_{\max} \cos(\omega t + \theta_i) \quad [\text{A}]$$

where V_{\max} and I_{\max} are the respective peak amplitudes of voltage and current, and θ_v and θ_i are the respective phase angles.

Then, by using trigonometric identities, the instantaneous power becomes:

$$p(t) = V_{\max} I_{\max} \cos(\omega t + \theta_v) \cos(\omega t + \theta_i)$$
$$= \frac{1}{2} V_{\max} I_{\max} [\cos(\theta_v - \theta_i) + \cos(2\omega t + \theta_v + \theta_i)]$$

Note that the final expression for $p(t)$ is composed of two parts, a constant (or average) component, and an oscillating

Poor self-inductive properties, due primarily to improper winding of the cable, and parasitic capacitance are the main culprits responsible for the loss of inductive phase angle in audio cable at low audio frequencies. This loss of phase angle causes a higher (worse) power factor.

On the instantaneous power plot, values of power that are above the zero line indicate power that is being absorbed by the network, and values that fall below the zero line represent power that the network is supplying back to itself. To calculate the power consumed over a period, the area underneath the power curve is determined using calculus. As we will see next, this is known as the active power.

An energy storage element absorbing power is analogous to a sponge absorbing water.

term that contains $2\omega t$. This term shows that instantaneous power oscillates at twice the applied frequency, as can be seen in the plot of Figure 6-1.

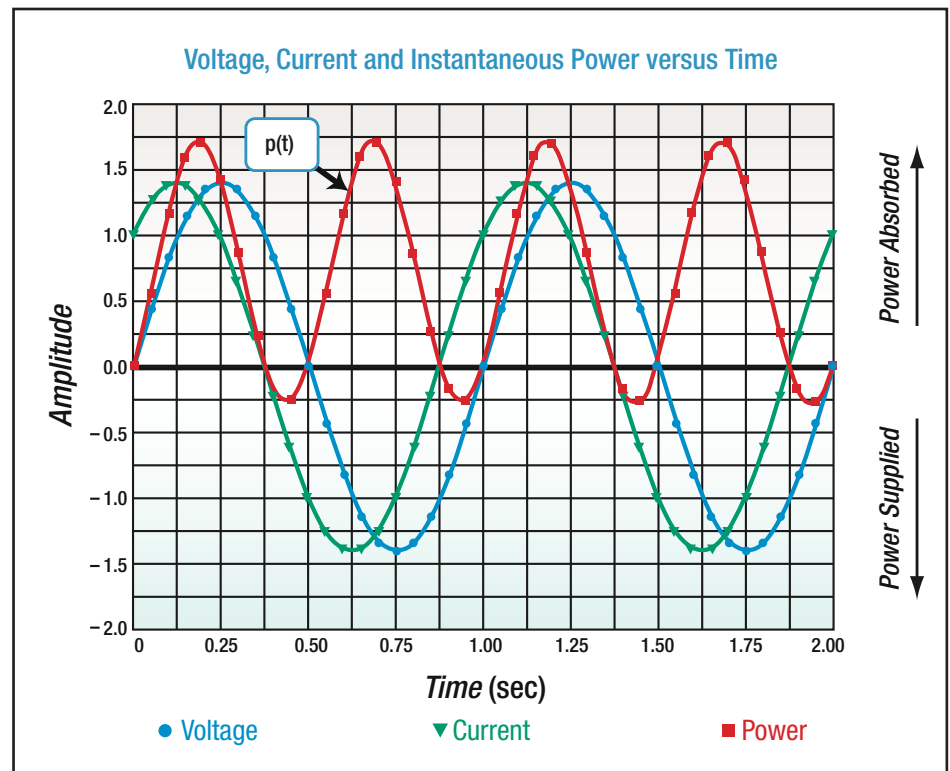

Figure 6-1. Plot of voltage, current, and the associated instantaneous power versus time. This shows that AC power is oscillatory in nature (unlike DC power), and changes sign four times per period, while the voltage and current waveforms change sign twice. For this plot, a network with an impedance phase angle of 45° was used to calculate the power values. Notice how the power plot oscillates mostly above the zero line, indicating that all of the power absorbed by the network has not been returned the signs of an inefficient network. Because the area of the power plot is not zero, this network has consumed power.

The sign for $p(t)$ can be both negative as well as positive. A positive value for $p(t)$ indicates that the device (or network) is absorbing the applied power, while a negative value shows that the device or network is supplying or returning power to the network. A note about terminology: Absorb and consume mean different

Pure or ideal reactive components, such as capacitors and inductors, return all of the energy they absorb back to the network. Resistors, on the other hand, dissipate all of the energy they absorb as heat.

Pure capacitors and inductors only temporarily store energy, then “squirt” it back into the network as power.

Active power is the time average of the instantaneous power taken over one period. In other words, average power is the area of the instantaneous power plot taken about the zero line. Average power is usually simply known as the power. The final result of the active power calculation is a single, scalar number it cannot be plotted versus time.

things when applied to how electrical power is handled in different circuit elements. When power is applied to an ideal resistor, that power is actually dissipated as heat into the environment, never to return to the circuit. That is, a resistor consumes all of the power applied to it. An ideal capacitor or inductor, however, treats power differently. During the first quarter of a period (90), when AC power is applied to a storage element, the energy is first stored in the element’s energy field—an electric field in a capacitor and a magnetic field in an inductor. From the point of view of the power source, the power it has output to the network has now been absorbed. But during the second quarter of the period, all of the energy that was stored in the ideal capacitor and inductor is released (or “squirted”) back into the network as power available for consumption by the load. This is different from the resistor, where power was dissipated as heat.

► Active power:

Active power (P) is of the most interest to us, since it is the power that is ultimately intended for consumption by the load. Active power is given by

$$P = \frac{1}{T} \int_0^T p(t) dt \quad [W]$$

Active power depends not only on the magnitudes of voltage and current, but also on the relative phase angle of the voltage and current in the network.

The familiar units of watts signifies active power is the type of power we should be interested in, since it will be consumed by the load

Because active power depends on the phase-angle difference between the voltage and current, the value of active power can change even if the magnitudes of voltage and current stay the same. This is unlike the case of DC power, where there is no phase angle to contend with.

where T is the period, in seconds, of the input signal.

From this we obtain:

$$P = \frac{1}{2} V_{\max} I_{\max} \cos(\theta_v - \theta_i) \quad [W]$$

where V_{\max} and I_{\max} are the amplitudes of the voltage and current, respectively; θ_v is the phase angle of the voltage; and θ_i is the phase angle of the current. P is given in units of Watts (W).

The familiar unit of watts suggests that this is the type of power we should be most interested in, since this is the power that is ultimately consumed by the load. Notice that unlike DC, the power in an AC circuit cannot be found simply by multiplying voltage and current; the respective phase angles of voltage and current must also be factored in. Because active power has the cosine function in it, it is defined as in-phase power.

A cable should accept the input apparent power and transport it as active power to the load. Active power is also known as average power, since it is the average amount of power that is consumed or supplied over one period of the input signal. It is important to note that not only does active power depend on the amplitudes of voltage and current, but also on the phase difference between them! Therefore, a change in the phase angle of the voltage or current can change the value of active power. This is different from

DC, where the value of power depended only on the magnitudes of voltage and current.

Reactive power is non-consumable power. This is the power that is absorbed. The audio signal that is input to the cable is stored as reactive power within the reactive elements (energy storage elements) temporarily. The energy storage elements then release the reactive power back to the network, generating consumable active power.

► Reactive power:

Reactive power (Q) is power that is temporarily stored in the reactive elements in a cable and returned back to the network.

Reactive power is given by

$$Q = \frac{1}{2} V_{\max} I_{\max} \sin(\theta_v - \theta_i) \quad [\text{VAr}]$$

where the unit for Q is Voltamperes reactive (VAr). Reactive power is also known as quadrature power, hence the Q (do not confuse this Q with the quality factor Q used in amplifier and filter design. There just are not enough symbols to go around!). Q, like P, also depends on the phase angles of voltage and current.

[The Role of Active & Reactive Power in Audio Cables](#)

In the introduction, we stated that capacitors and inductors are energy-storage elements. In terms of power, this means that ideal energy storage elements do not consume power, rather, they only temporarily store reactive power, as shown in Figure 6-2. Compare with the power characteristics of a resistor (Figure 6-3), in which all power is dissipated and none is stored. Thus, in an ideal audio cable, the power transportation process is this: The

The more pure and ideal the capacitive and inductive elements of the cable are, the more efficiently the cable will store and release reactive power.

Notice how the capacitor returns all of the power it has absorbed. If this capacitor is part of a network, such as an audio cable, then the power it returns would flow back into the network.

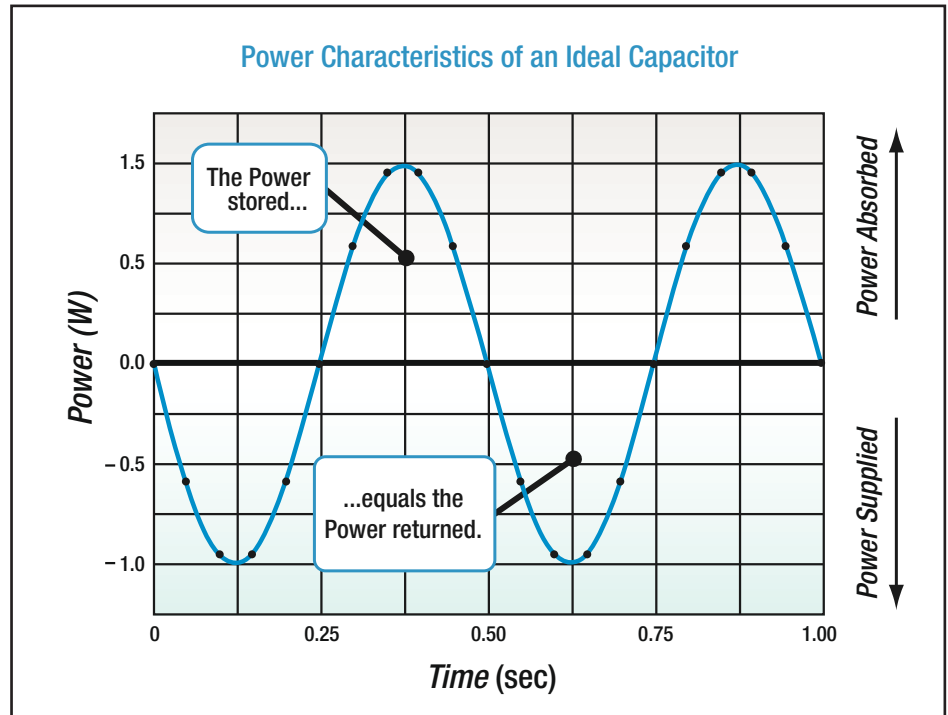

Figure 6-2. The power characteristics of an ideal capacitor. Since the power plot oscillates evenly above and below the zero line, the power stored cancels the power absorbed; the net effect is that an ideal capacitor consumes no power.

Notice how the resistor dissipates all of the power input to it, rather than returning the power back to the network as does an ideal capacitor or inductor.

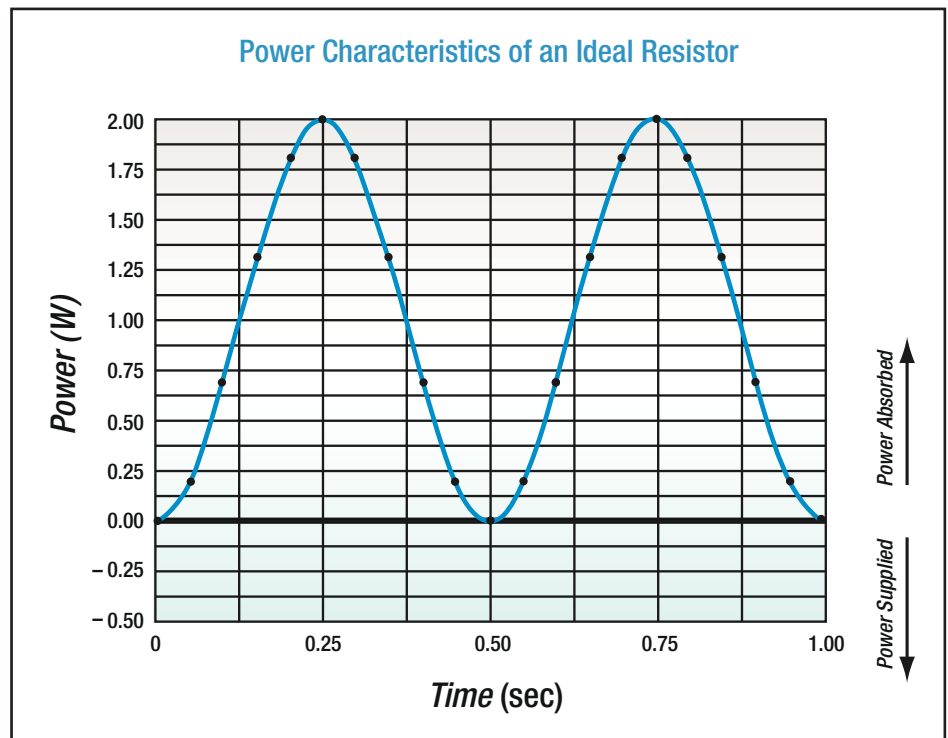

Figure 6-3. The power characteristics of an ideal resistor. Since the power plot oscillates completely above the zero line, an ideal resistor consumes all of the power input to it.

How efficiently the capacitive and inductive components of a cable absorb and return power is a critical factor in the cable's performance within an audio system.

cable will absorb the input apparent power and store the voltage in its shunt capacitance and the current in its inductance as reactive power. This reactive power is then returned back to the network as active power that is transported onward to the load for consumption. If the proper amounts of capacitance and inductance are present, all of this will happen in phase with the applied signal, and active power will be supplied to the load. We will show in the following chapters what happens when the amounts of reactance are not proper.

7. The Power Factor

Using the power factor, one can determine the ability of any passive coupling network to transport power.

Cables that are properly wound have better self and mutual inductive properties and therefore will have better power-factor characteristics.

Ohm's Law states that the phase difference between the voltage and current is equal to the phase angle of the impedance. The impedance phase angle can be measured and used to calculate the power factor.

In the previous chapters we have made the point that a cable with poor impedance phase characteristics will have problems transporting active power, because improper phase angles will lead to an undesirable power factor. In this chapter, we will put everything together to show how the phase angles and power factor are related.

The question arises, how are these phase angles measured? Recall from the phasor form of Ohm's law that the phase difference of the voltage and current is equal to the phase angle of the impedance:

$$Z \angle \Theta_z = \frac{V \angle \Theta_v}{I \angle \Theta_i}$$

which reduces to

$$Z \angle \Theta_z = \frac{V}{I} \angle (\Theta_v - \Theta_i)$$

therefore

$$\Theta_z = \Theta_v - \Theta_i$$

This is an extremely important result. The phase angle of the impedance is a quantity that can be measured directly using an impedance analyzer. Thus, insight can be gained about the relative phase angle of the voltage and current in an audio cable simply by looking at its impedance. Recall that this phase difference

quantity appeared in the equations for power presented in the last section.

Calculating the Power Factor

The power factor is defined as

$$PF = \cos(\Theta_v - \Theta_i)$$

The power factor is calculated by taking the cosine of the power factor angle.

However, the power factor is usually given as

$$PF = \cos(\Theta) \quad [\text{unitless}]$$

where Θ , the phase difference between the voltage and current, is known as the power factor angle.

Since we can measure the impedance phase angle of cable, we can calculate the power factor of audio cable by simply taking the cosine of our measurement. We can then use the power factor as a tool to characterize how efficiently an audio cable is functioning as a coupling network.

A Word of Caution About Power Factors and the Like

The power factor is but one of many criteria that need to be used together to fully characterize an audio cable's performance.

While the power factor is an excellent way of “grading” audio cables by efficiency of power transfer, it is not the only criterion. The complete role of a coupling network, such as an audio cable, is very complicated, and no single measurement or criterion will completely specify how well an audio cable satisfies that role. To fully analyze an audio cable, several measurements must be com

The power factor is an important step in characterizing audio cable, but complete analog behavioral modeling of a cable requires more than the power factor alone.

bined. These include, but are not limited to: the gain/phase transfer function, impedance transfer function, time-domain impulse and unit-step response testing, and circuit modeling based on all of the above. Furthermore, if required, other behavior can also be analyzed to specifically focus attention in a desired area. However, the measurements listed above are sufficient to reveal the majority of the information required. These measurements and other topics will be considered for other papers.

The Power Factor of Audio Cable Energy Storage Elements

An ideal capacitor has a power factor of zero. This indicates that all the applied (apparent) power is stored within the capacitor as reactive power. Compare with an ideal resistor, which has an impedance phase angle of 0 degrees. The power factor of a resistor would then be: $PF = \cos(0) = 1$, indicating that the resistor dissipates all of the power input to it.

► Ideal Capacitors:

An ideal capacitor has a phase angle of -90 degrees. Therefore, the power factor (PF) is:

$$PF = \cos(-90) = 0$$

Since an ideal capacitor dissipates no energy (active power), a power factor of 0 indicates a lossless device, and that all the applied power (apparent power) is stored as reactive power within the element.

► Ideal Inductors:

An ideal inductor has a phase angle of +90 degrees, and therefore the power factor is:

$$PF = \cos(90) = 0$$

An ideal inductor has a power factor of zero. Like the ideal capacitor, all the applied (apparent) power is stored within the inductor as reactive power.

Again, as with the ideal capacitor, the ideal inductor is shown to be a lossless element it stores all of the apparent power as reactive power.

► Non-Ideal Capacitor:

Suppose, however, that a capacitor has a measured phase angle

The power factor then becomes:

$$PF = \cos(-75) = 0.259$$

Since the cosine function always varies between 0.0 and 1.0, the power factor can be used as an efficiency-scaling factor. In power engineering, the sign of the power factor is disregarded, since it is ambiguous. Recall that the cosine is an even function, so $\cos(90) = \cos(-90) = 0$. Therefore no distinction can be made from the power factor alone whether an element is capacitive or reactive.

► Non-Ideal Inductor:

A non-ideal inductor might have a phase angle of 35 degrees. This results in a power factor of:

$$PF = \cos(35) = 0.819$$

A power factor of 0.819 indicates that the inductor is returning only 18.1% of the energy stored in its magnetic flux back to the network in phase. This does not mean, however, the inductor is dissipating the difference (81.9%) in energy as heat. The power factor tells us only what percentage of the apparent power is being

In a practical capacitor, the phase angle is less than -90 degrees (-85 degrees, for example), and the power factor is greater than zero.

In a real-world inductor, the phase angle is less than 90 degrees, and the power factor is greater than zero.

The power factor gives the ratio of active power to apparent power. In other words, the power factor is the ratio of power consumed by the network to the input power.

returned back to the network in phase with the input as active power. This represents usable power to the load. The power factor does not indicate whether the remainder of the apparent power is being dissipated within the element, reflected back to the source, or released back to the network out of phase.

The Power Factor of an Audio Cable Model

► Ideal Model:

In general, MIT views audio cable as a series inductor in parallel with a capacitor, as shown in Fig. 7-1 An ideal circuit cable model would then be the circuit of Figure 7-2.

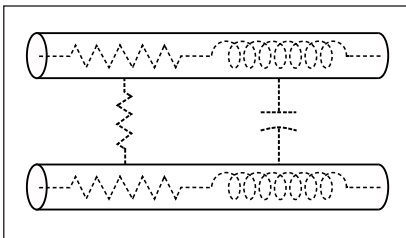

Figure 7-1. The Audio Cable Network: The two conductors of the cable form the plates of a capacitor, while the windings of the conductors form inductors.

To examine the power factor of this model, let's assume the inductor has a value of 1mH, the capacitor has a value of 100pF, and the input frequency is 100Hz.

The inductive reactance (X_L) is found from:

$$X_L = 2\pi fL = 2\pi(100)(0.001) = 0.628\Omega$$

The inductor phasor is then:

$$\vec{Z}_L = 0.628\Omega \angle 90^\circ$$

The capacitive reactance (X_C) is found from:

$$X_C = \frac{1}{2\pi fC} = \frac{1}{2\pi(100)(100 \times 10^{-9})} = 15.9k\Omega$$

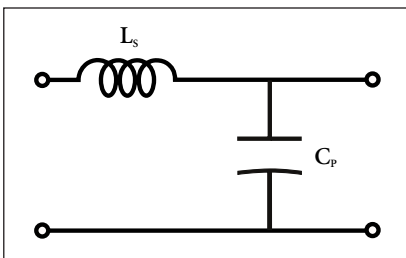

Figure 7-2. Ideal model of an audio cable, using discrete components

Note the ideal phase angles of -90 degrees for Z_C and 90 degrees for Z_L.

The capacitive phasor (Z_C) is then:

$$\vec{Z}_C = 15.9k\Omega \angle -90^\circ$$

Next, the equivalent impedance (Z_{eq}) can be found. The parallel impedance of a two-element circuit can be obtained from:

$$\vec{Z}_{eq} = \frac{(Z_C)(Z_L)}{(Z_C + Z_L)}$$

which yields:

$$\vec{Z}_{eq} = 0.628\Omega \angle 90^\circ$$

The power factor of this network is then:

$$PF = \cos(\angle Z_{eq}) = \cos(90) = 0$$

The power factor of the ideal model of audio cable is zero. This means that the ideal audio cable stores applied power as reactive power to be released as active power back to the network. An ideal situation, then, would have an ideal audio cable with a power factor of 0 connected to an ideal load which has a power factor of 1. This way, we can assume that that all of the music has been transported to the load and consumed!

This is a very important result. It means that an ideal audio cable would have a power factor of 0. This implies that an ideal audio cable stores all (100%) of the apparent power in the reactive elements as reactive power, and then returns the reactive power back to the network as in-phase active power to be consumed by the load. The 0 power factor also implies that an ideal audio cable does not dissipate any energy within its own network (it has no resistance).

► Non-Ideal Model:

The non-ideal, or non-linear, model takes into account the parasitics of the real-world audio cable. For the purposes of this paper,

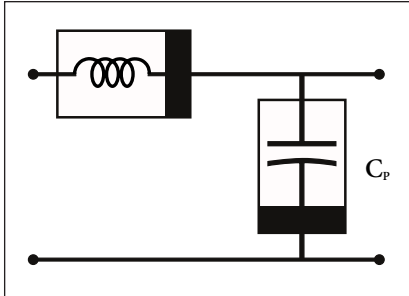

Figure 7-3. Non-linear model of audio cable.

Note that the phase angle of the capacitive component is very nearly ideal (-89.5 degrees), while the inductive component is extremely poor (+5.00 degrees). These are fairly common measured values for most audio cables when measured at 100Hz or less.

A power factor of 0.996 is very poor for an audio cable.

we will use the non-linear circuit symbols rather than specifying each parasitic's measured value. The non-ideal audio cable circuit model then becomes the circuit of Figure 7-3.

The values of the non-linear components are the actual measured phasor values of the cable. To repeat an important point: Since musical energy is AC, not DC energy, MIT measures the complex impedance (magnitude and phase angle) of audio cable over the entire audio frequency range in order to characterize its performance in the audio environment. Measured at 100Hz, typical impedance values of audio cable might be:

$$\vec{Z}_c = 50k\Omega \angle -89.5^\circ$$

and

$$\vec{Z}_l = 0.001\Omega \angle 5.00^\circ$$

Taking the parallel combination as before yields:

$$\vec{Z}_{eq} = 0.001\Omega \angle 5.00^\circ$$

Notice how the equivalent impedance of audio cable is influenced mainly by the inductive component.) The power factor of our practical example is then:

$$PF = \cos(5.00) = 0.996$$

While this number may seem surprising, this is indeed a very common measure of audio cable at 100Hz.

As before, this result tells us that 99.6% of the apparent power at 100Hz is not being returned to the network as in phase active power to be transported to the load. Conversely, 0.4% is being transported as useful in-phase active power to the load. As can be seen, audio cables typically have problems transporting active power at these low audio frequencies.

Let's look, however, at a typical cable at 20kHz:

$$\vec{Z}_c = 20.93k\Omega \angle -85.40^\circ$$

$$\vec{Z}_l = 1.05\Omega \angle -82.20^\circ$$

$$\vec{Z}_{eq} = 1.05\Omega \angle -82.199^\circ$$

for a power factor of:

$$PF = \cos(82.199) = 0.136$$

The high audio frequency power characteristics of this typical cable are much better than its low audio frequency characteristics.

Most audio cables have very poor power factors at low audio frequencies. This is mainly due to poor inductive phase-angle properties at low frequencies.

Note how the inductive phase angle has increased dramatically at 20kHz. The power factor then shows the corresponding improvement. A cable with a good (lower) power factor is transporting most of its power as in-phase power.

8. Test and Measurement Results

[How Tests Reveal the Characteristics of Audio Cables](#)

Past articles written about audio cables often neglect the fact that the impedance phase angles can change with frequency.

MIT's measurements show that an audio cable's impedance phase angle changes with frequency. Because of this, the power factor also changes with frequency. In short, MIT has shown that the power-transfer characteristics of audio cable are frequency dependent. Having discovered this, MIT designs cables to produce a more linear power-factor characteristic through the audio frequency spectrum.

Earlier, in the section on energy storage elements, we showed how capacitive and inductive reactances of ideal components change with frequency. But what about the phase angles of the elements (L and C) do they change with frequency? Many articles have been written about modeling audio cable using the discrete components L, C, and R. But all have one major pitfall, they assume that the impedance phase angles of these components are ideal and therefore stay constant over the audio frequency range. This is not the case. Our measurements will show that the inductive and capacitive phase angles of an audio cable actually change with frequency, particularly below about 1kHz. This has a major implication: If the impedance phase angle changes with frequency, then the power factor changes with frequency. This means that the cable's power-handling characteristics are frequency dependent. Furthermore, the total composition of power (the ratio of active power to apparent power, and the mix of active and reactive power) is also frequency dependent.

[Measurement Set-Up](#)

To measure the impedance phase angles, we used a Hewlett-Packard 4284A Precision LCR analyzer. Under computer control, measurements were taken from 20Hz to 20kHz, with resolutions

Proper analog modeling techniques require that many measurements be taken across a wide range of frequencies. However, the process is not as easy for multi-gauge cable. Because each of the separate gauges has its own unique self-inductive signature, each gauge must be measured separately and the data combined mathematically.

The particular test cables used in our tests were chosen by the following criteria: The popular zip-cord type cable is one that is sold world-wide and is often the consumer's first purchase when beginning the path of upgrading his or her audio system. The multi-gauge and braided cables are popular High End cables and recommended by many High-End reviewers.

as high as 2000 points. The oscillator output level was set to 1 volt. From these measurements, the power factor was calculated and plotted.

A test and measurement note: Measuring a multi-gauge audio cable is more complicated than measuring a zip-cord-type cable. In a multi-gauge cable, each gauge conductor must be measured separately and the data re-assembled mathematically. This process is beyond the scope of this paper and will be considered as a separate paper in the future.

Measurement Results

Measurement results for four different audio cables are presented in Graphs 1 and 2; a fifth ideal cable has been added to show an ideal response for comparison. The four test cables are:

- A. MIT Reference Speaker Cable
- B. Popular Zip-Cord Type Cable
- C. High End Multi-Gauge Cable
- D. High End Braided Coaxial Cable
- E. Ideal Cable

No cable is ideal, so a cable can never have a power factor of zero. The goal, then, is to not only have the power factor as low as possible, but also to have the power factor be as linear to frequency as possible.

Graph 1 shows that, below 2000 Hz, the MIT reference speaker cable has the lowest power factor. This means that it is transporting musical energy in this frequency range the most efficiently.

Graph 1 also shows that, while the other cables' power factor changes dramatically with frequency, the MIT cable comes closest to having a power factor that is constant with frequency closest to the ideal cable. This results in a more linear system response, because musical energy of all frequencies is transported through the cable more equally.

Graph 1:

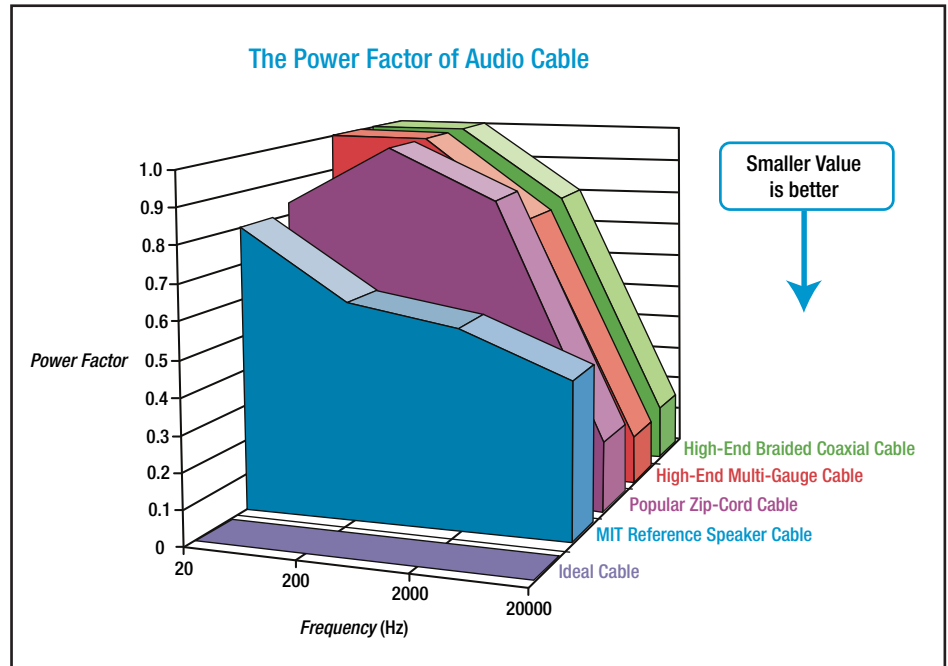

Graph 1 shows the power factor of the test cables versus frequency. The power factor was computed from measured impedance data. The plot clearly shows that below 2000Hz, our own reference cable is the only one here to effectively store and then transport low-frequency energy, as shown by the lowest power factor. This is because our reference cable is the only one providing proper inductive qualities at low audio frequencies.

Furthermore, the reference cable shows the most linear power factor when plotted versus frequency. This is the result of our design criterion aimed at constantly holding proper inductive qualities not only at low frequencies, but throughout the audio range.

Linear inductive phase angles lead to linear impedance phase angles, which result in linear power factor response.

Because the reference cable's power factor does not vary as widely versus frequency as the other cables, the result is a more linear transportation of in-phase active power to the load.

Graph 2

Graph 2 shows how much active power versus frequency the cable is transporting. The goal is to have the cable transport the same percentage of active power at all frequencies. If this does not happen, then the cable will emphasize those frequencies that it transports power well in, and de-emphasize those parts of the spectrum that it does not transport power in.

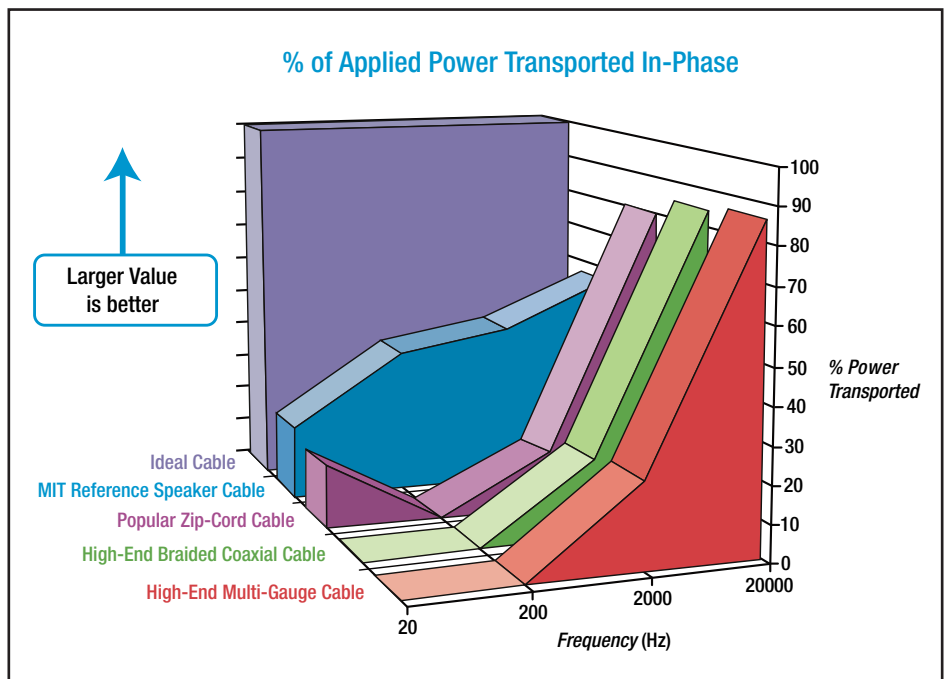

Graph 2 shows a different way of interpreting the power factor. This graph shows what percent of the applied power at a specific frequency is being transported by the cable to the load as active (in-phase) power.

The percent of applied power transported is calculated from

$$\% \text{ Power Transported} = 100 \times (1 - \text{PF}) \quad [\%]$$

Power that is not transported in phase may still be transported to the load. But it will be out-of-phase power.

The result of a design using the power factor to assess a cable's ability to transport power is apparent in Graph 2. While not perfect, the MIT reference cable comes closest to the ideal cable. MIT is committed to improving this ability in its own products in the future.

This is an important graph, because it shows the relative effects of audio cable on the system. The ideal cable plot shows that it does not emphasize or de-emphasize any frequency; it transports power in a perfectly ideal and linear fashion throughout the audio spectrum. The plots for the multi-gauge, coaxial, and zip-cord cables show that, relatively speaking, they de-emphasize low-frequency energy, while high-frequency energy is over-emphasized.

The plot for the MIT cable, while not perfect, shows the most linear power response of the group. No part of the spectrum is emphasized or de-emphasized as greatly as in the other cables.

[Conclusions from Test Results](#)

Through the use of the power factor, we at MIT have been led to conclude that a poor power factor is a mechanism for distortion. That is, that networks exhibiting poor power factor transport and play in-phase music along with out-of-phase music simultaneously. What level of this distortion is audible? We are continuing our research in this area.

The test results demonstrate the effectiveness of a design that begins to overcome such engineering problems as the power factor at low frequencies. The networks within MIT's reference speaker cable provide individual inductive pathways allowing for more efficient transportation of musical energy at all audio frequencies. These test results clearly show the role these networks play in transporting active power to the load for consumption. MIT is committed to improving the efficiency of power transportation in all of its audio cables in the future.

Appendix A—Capacitor Characteristics

Ideal Capacitor

Figure 1. Phasor plot for an ideal capacitor.

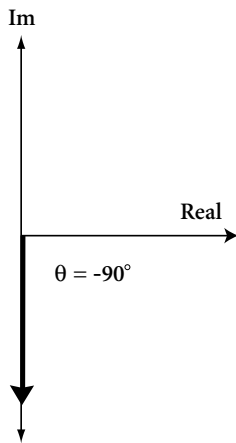
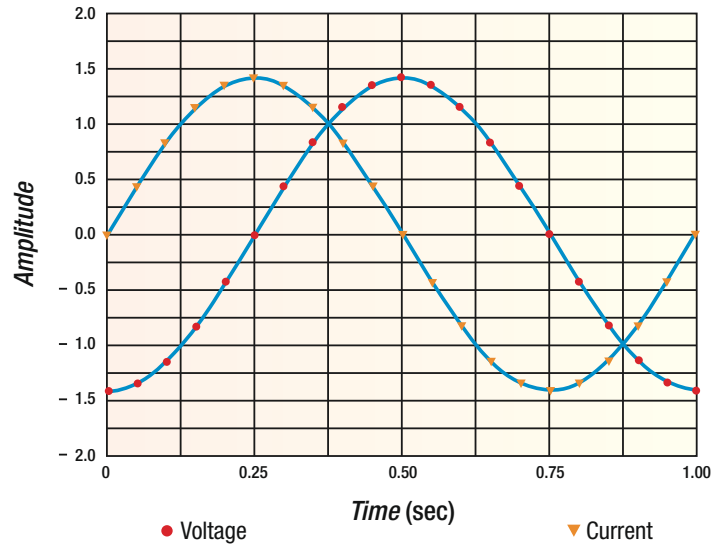

Figure 2.

Voltage and Current Plot for an Ideal Capacitor



Non-Ideal Capacitor

Figure 3. Phasor plot for a non-ideal capacitor.

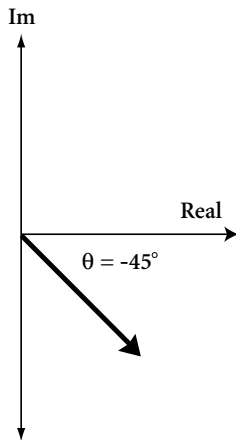
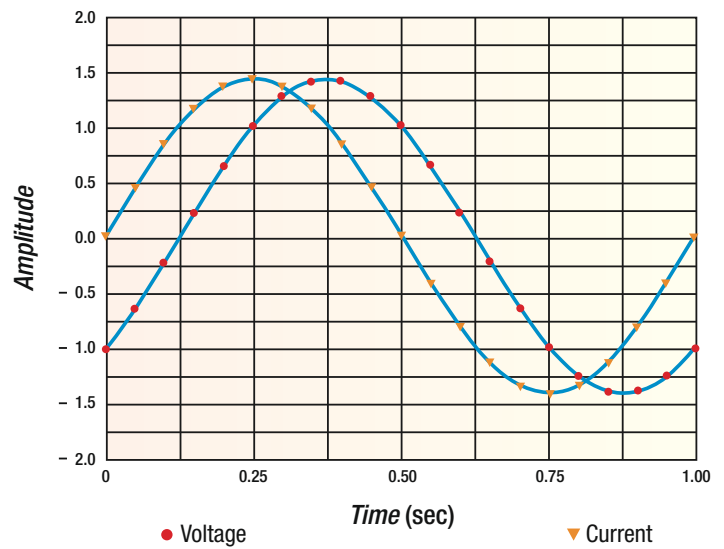

Figure 4.

Voltage and Current Plot for a Non-Ideal Capacitor



Appendix B—Inductor Characteristics

Ideal Inductor

Figure 1. Phasor plot for an ideal inductor.

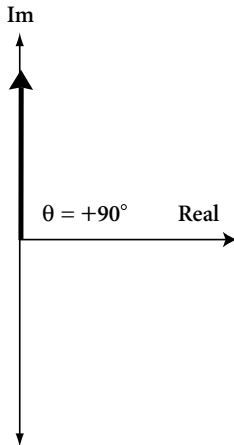
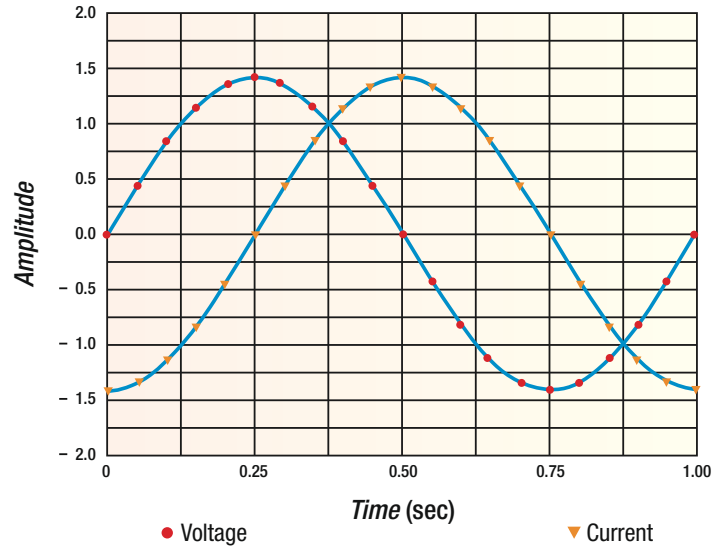

Figure 2.

Voltage and Current Plot for an Ideal Inductor



Non-Ideal Inductor

Figure 3. Phasor plot for a non-ideal inductor.

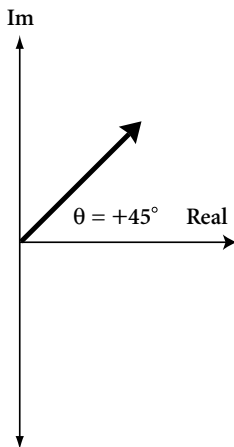
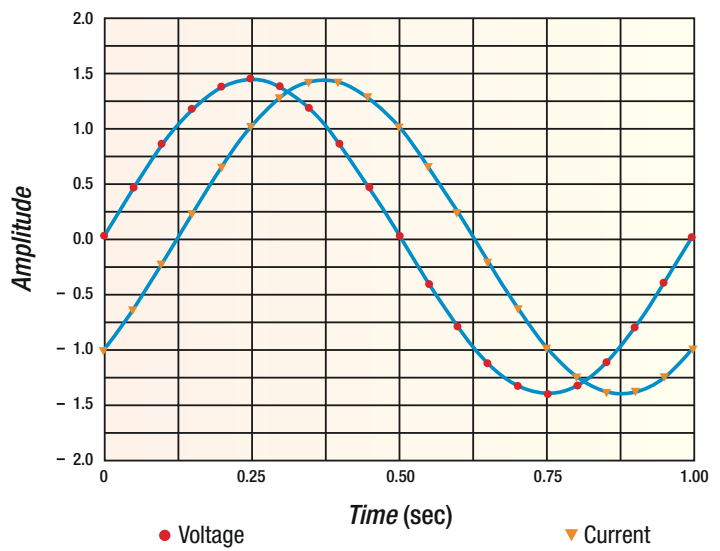

Figure 4.

Voltage and Current Plot for a Non-Ideal Conductor



Appendix C—References

For a well-written general circuit analysis text with excellent treatments of impedance, reactive elements, and AC analysis, see the following book:

Paul, Clayton R.—Analysis of Linear Circuits. New York, NY: McGraw-Hill, 1989.

For further information on power and the derivations used in this paper, see the following book:

Bergen, Arthur R.—Power Systems Analysis. Englewood Cliffs, NJ: Prentice-Hall, 1986.

Acknowledgements

For the past 14 years, Bruce Brisson has been designing cables, first for himself, then from 1981-1983 for Monster Cable Company, and after 1983 for his own company, Music Interface Technologies (MIT). During this time, he has collected his thinking on the backs of envelopes and in countless boxes of paper scraps. He'd like to thank Timothy Brisson for helping to assemble those notes and his accumulated test-and-measurement plots into a coherent work.

Throughout the writing process, Richard Marsh took time from his own designing to play the role of “Devil's Advocate”, which has gotten us to look at our own work from, we trust, all possible points of view.

Sallie Reynolds agreed to edit the results after we promised to make the paper as broadly comprehensible as possible, so it could serve as a learning tool for the reader.

Finally, a note about the Hewlett Packard Company. Particularly Dick Angus, who has his Black Belt in FFT analysis. When others would say, “You want to measure what?”, Dick would research the answers and come through with the proper test-and-measurement architecture for us. Thank you, Dick Angus, and thank you, Hewlett Packard. This company can stand as a role model for any industry.



Music Interface Technologies™

MIT products are manufactured and sold by CVTL, Inc.

4130 Citrus Ave #9, Rocklin, CA, USA 95677 Phone: 916/625-0129 Fax: 916/625-0149

www.mitcables.com